

FLEXA®

82-50081-40/-95

122 x 61 x 65/75cm

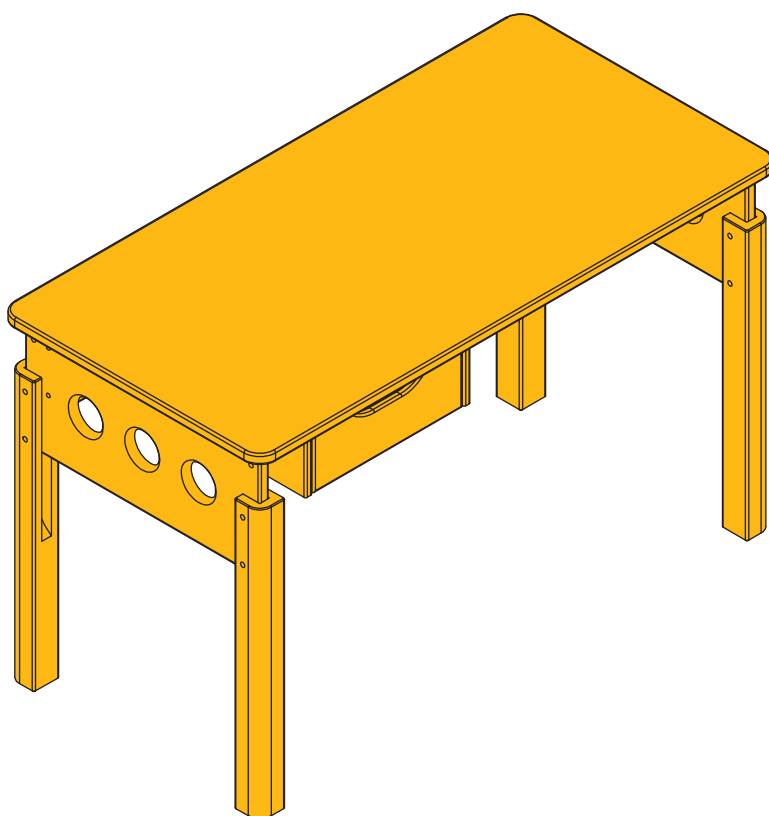

Monterings- og brugsvejledning
Assembly instructions and direction for use
Montageanleitung und Gebrauchsanweisung
Notice de montage et mode d'emploi
Montageinstructie en onderhouds voorschrift
Instrucciones de montaje y uso
Istruzioni di montaggio e uso
Kokoamis- ja käyttöohjeet
Οδηγίες συναρμολόγησης και χρήσης

Instrukcje montażu i wskazówki dotyczące użytkowania
Instruções de montagem e de utilização
Instrucțiuni de asamblare și recomandări de utilizare.
Инструкции по сборке и руководство использования
安装及使用说明
組立ておよび使用説明
รายละเอียดเกี่ยวกับวิธีการใช้
และการติดตั้ง
설치 및 취급설명

For indoor
domestic use

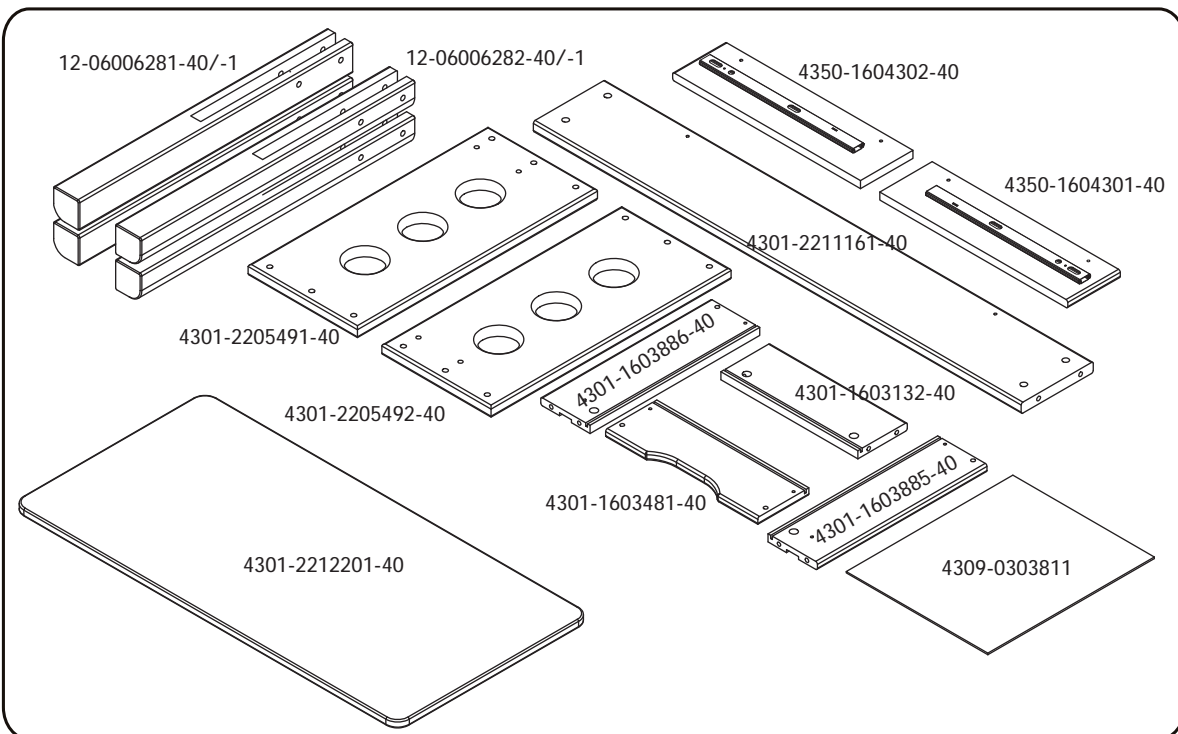
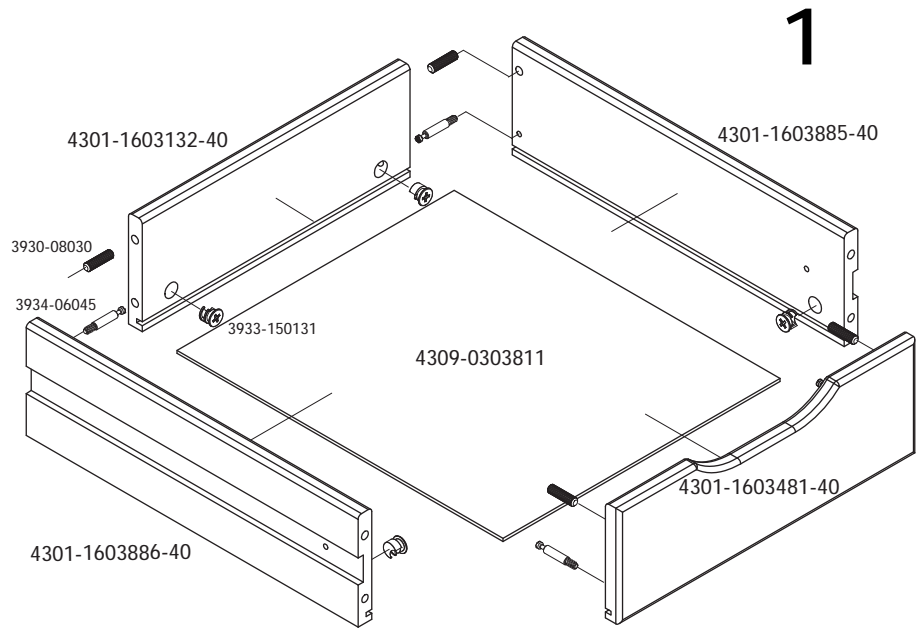
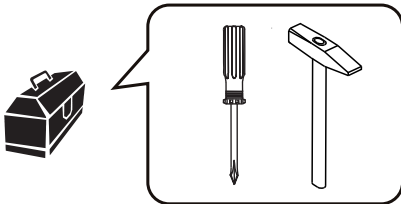
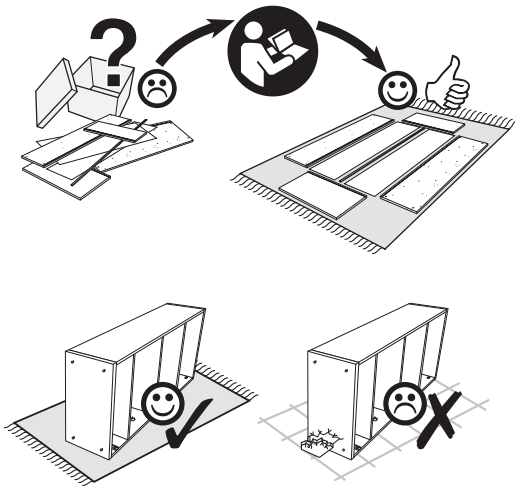
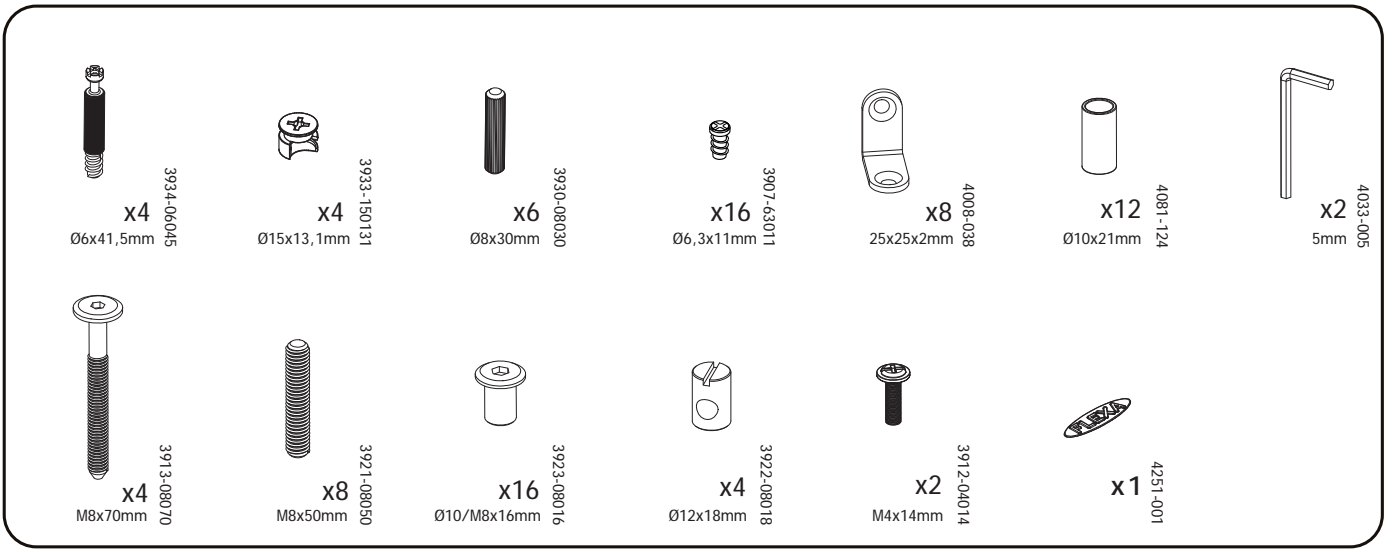

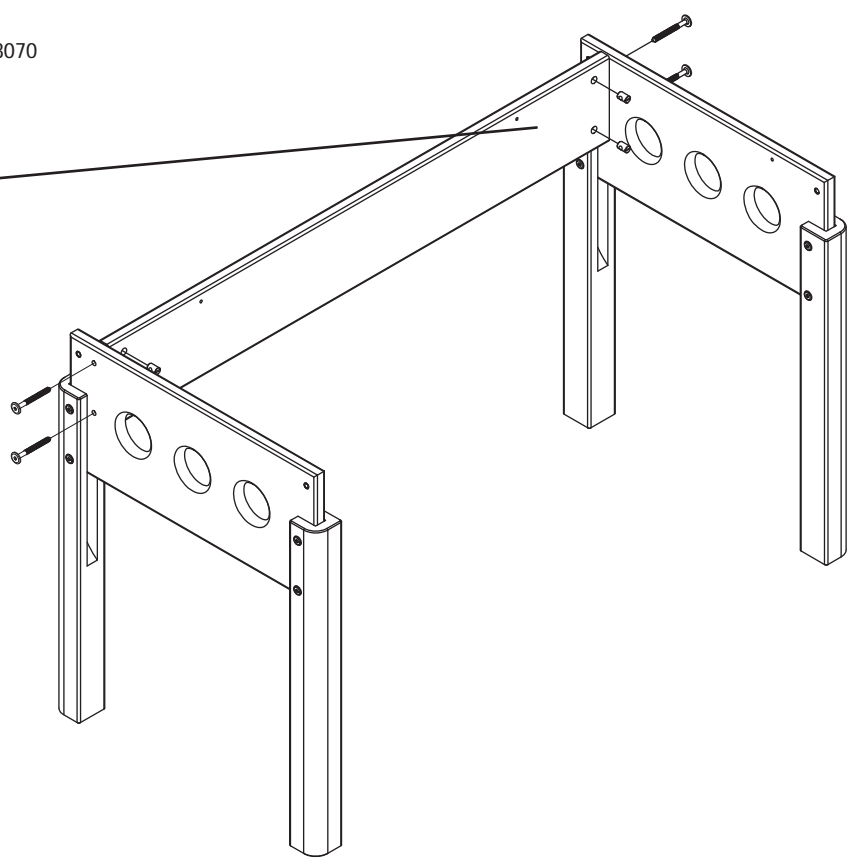
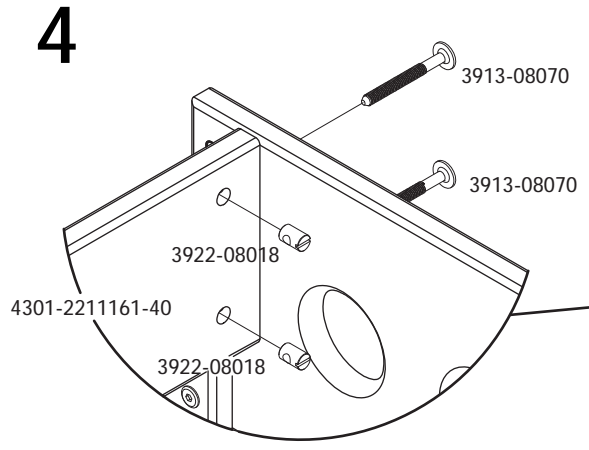
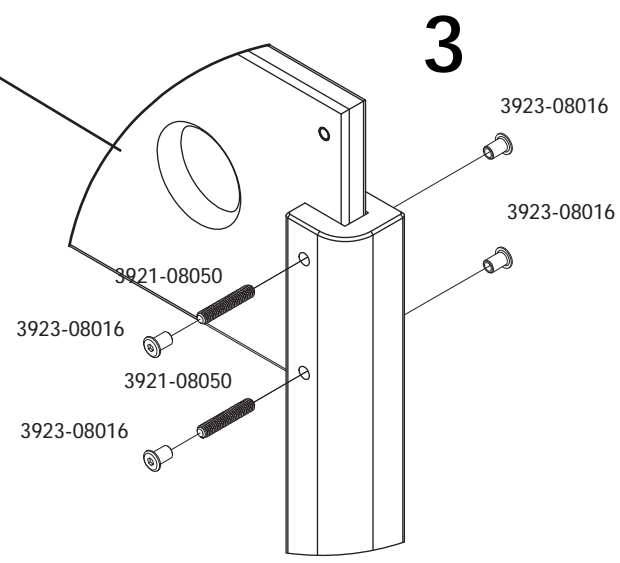
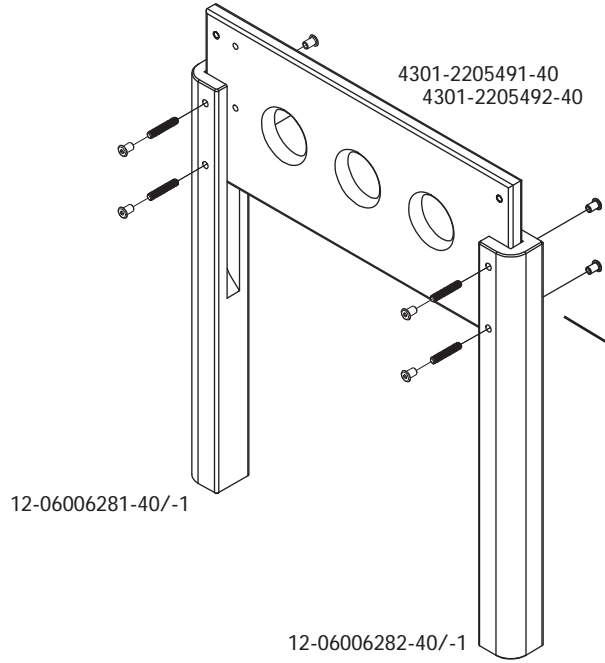
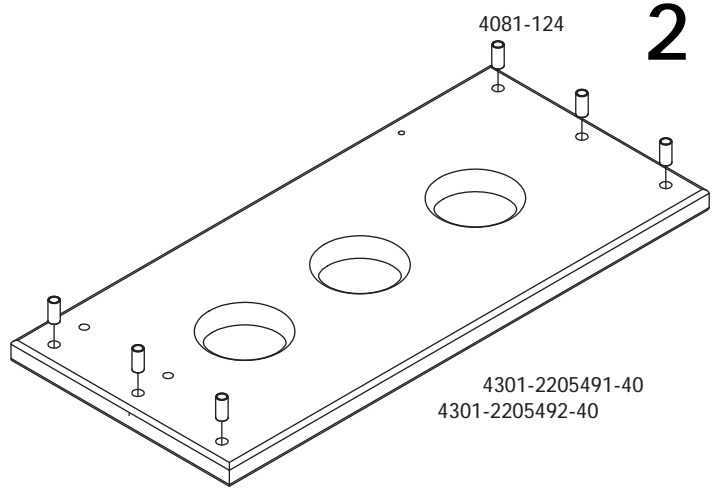

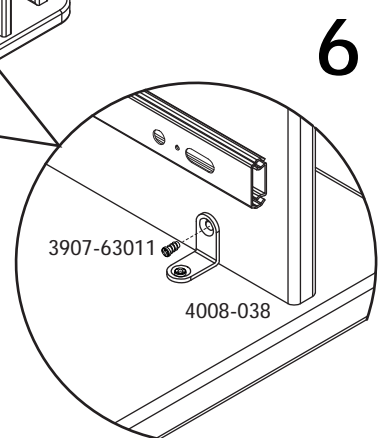
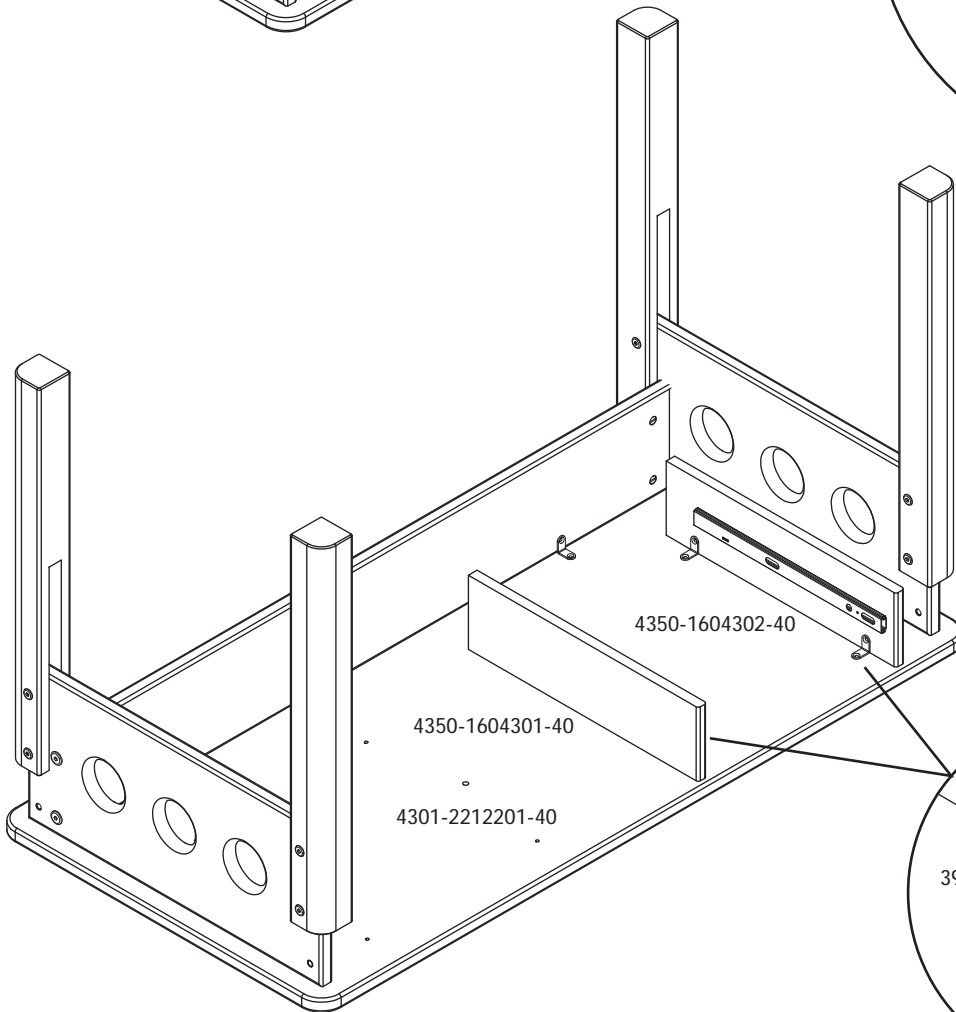
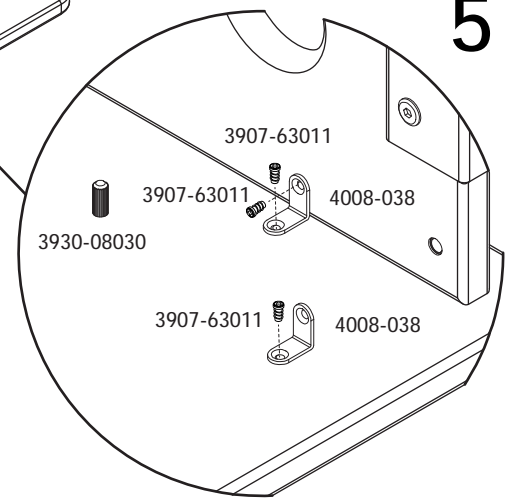
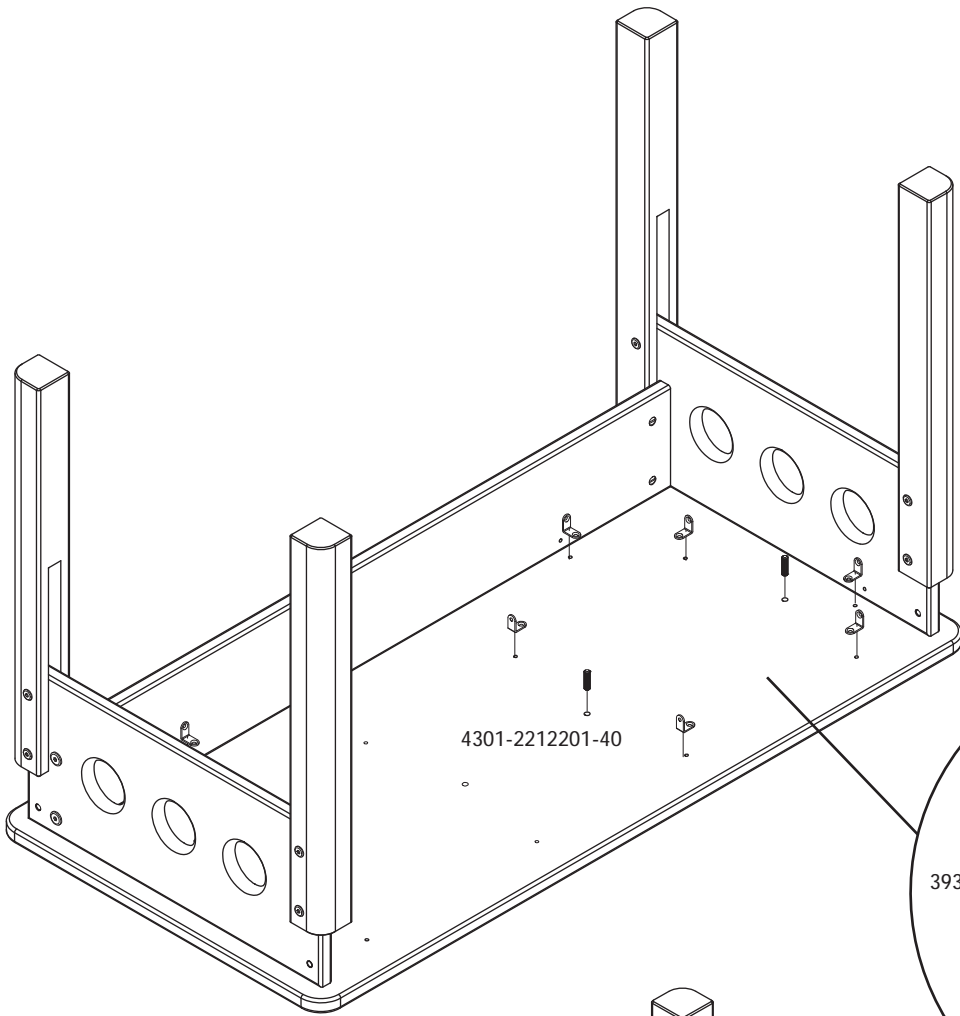

7

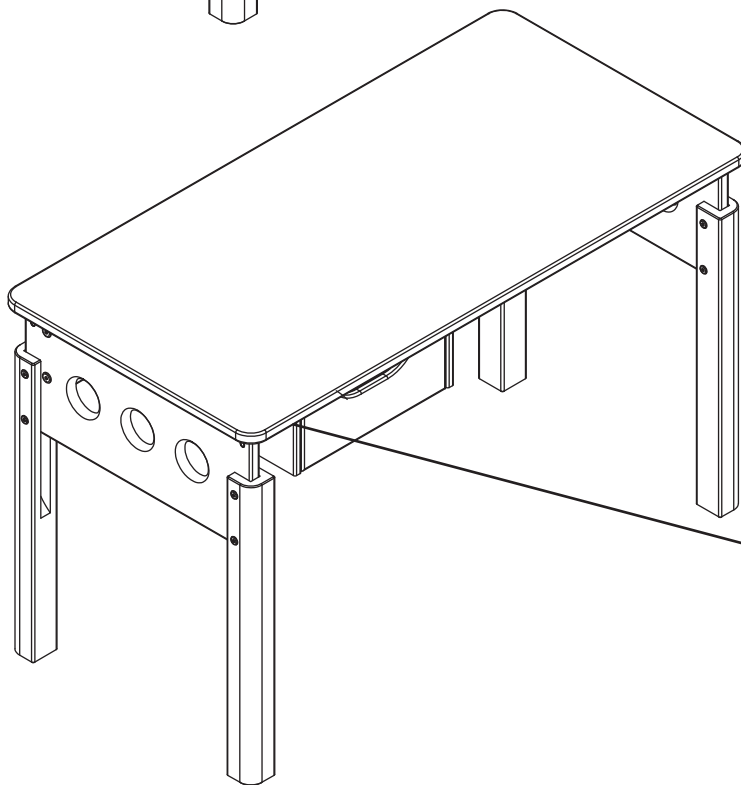
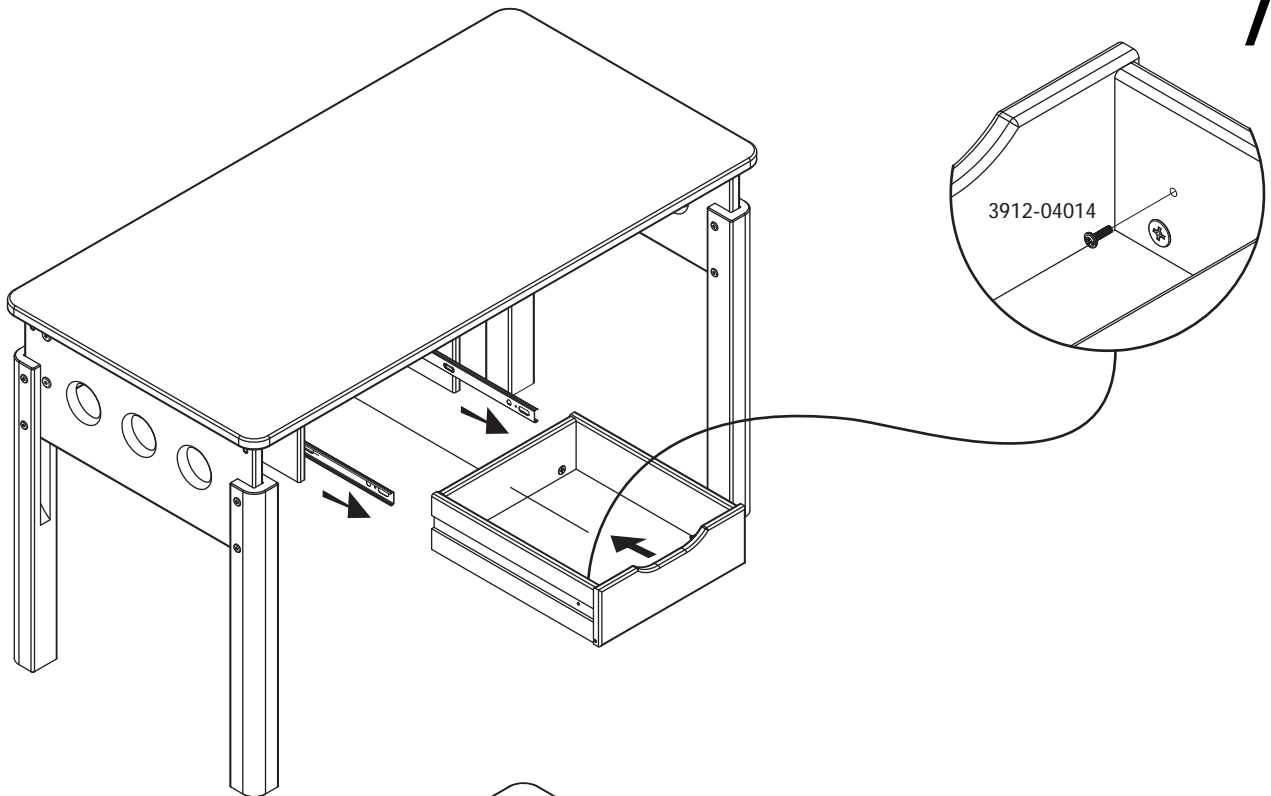

8

<p>(DK) RÅD OM VEDLIGEHOJDELSE: Tør af med en fugtig klud. Evt. større pletter fjernes med en fugtig svamp med sæbe. Undgå opløsningsmidler. Skruer og bolte efterspændes med jævne mellemrum.</p>	<p>(GB) MAINTENANCE INSTRUCTIONS: Cleaning with a wet cloth, use a sponge with soap to remove obstinate dirt. Avoid solvents and dilutions. Screws and bolts should from time to time be retightened.</p>	<p>(D) PFLEGEHINWEIS: Pflege mit einem feuchten Lappen. Für hartnäckigen Schmutz empfehlen wir einen Schwamm mit Seife. Vermeiden Sie Lösungs- und Verdünnungsmittel. Schrauben und Bolzen sollten regelmässig nachgezogen werden.</p>	<p>(F) CONSEILS D'ENTRETIEN: Entretien avec un chiffon humide pour la poussière - les tâches rebelles s'enlèvent avec une éponge légèrement savonneuse. Éviter tous solvants et diluants. Votre lit doit être vérifié périodiquement afin de resserrer les vis.</p>	<p>(E) CONSEJO PARA LA CONSERVACIÓN: Limpiar con un paño húmedo. Para quitar manchas mas grandes usar una esponja con jabón. Evitar usar productos quimicos. Las herrajes necesitan opretarse a veces</p>	<p>(NL) ONDERHOUD: Reinigen met een vochtige doek. Hardnekkig vuil verwijderen met een spons en zeep. Vermijd oplos- en verdunningsmiddelen. Schroeven en moeren regelmatig aandraaien.</p>	<p>(I) CONSIGLI PER LA MANUTENZIONE: Pulire con un panno umido, usare una spugna impregnata di sapone per togliere lo sporco persistente. Evitare l'uso de prodotti chimici. Dadi e viti sono, di tanto e tanto, da ri-avvitare.</p>
---	--	---	--	--	--	---